

Manitou Skid Steer Loader

1340 R



Technical Specifications

Capacities		Metric
Rated Operating Capacity		612 kg
Unladen weight		2200 kg
Tipping capacity		1224 kg
Weight and dimensions		
Overall Operating Height - Fully Raised	h27	3584 mm
Height to Hinge Pin – Fully Raised	h28	2794 mm
Overall Height to Top of ROPS	h17	1826 mm
Dump angle at full height	a5	42 °
Dump height	h29	2197 mm
Overall length with bucket	l16	2952 mm
Dump reach at full height		528 mm
Rollback at ground		29 °
Rollback Angle at Full Height	a4	990 °
Seat to ground height	h30	853 mm
Wheelbase	y	923 mm
Overall width less bucket	b1	1346 mm
Bucket Width	e1	1562 mm
Ground clearance	m4	211 mm
Overall length - Less Bucket	l2	2314 mm
Departure angle	a2	29 °
Clearance Radius - Front with Bucket		1758 mm
Clearance Circle - Front without Bucket	b19	1102 mm
Clearance Circle - Rear	wa1	1102 mm
Performances		
Travel speed (unladen)		10.70 km/h
Wheels		
Transmission type		Hydrostatic
Standard tyres		10X 16.5 - 10 PR Heavy Duty
Number of drive wheels		4
Engine		
Engine brand		Yanmar
Engine model		4TNV88
Engine norm		BS-III
Gross Power (kW)		49 Hp
Max. torque / Engine rotation		142 Nm / 1600 rpm
Power source		Diesel
Number of cylinders		4
Engine cooling system		Water cooled
Battery		12 V
Alternator		40 kW
Alternator - Ampere		55 A
Starter (kW)		3 kW
Hydraulics		
Auxiliary Hydraulic Pressure		190 Bar
High-Flow Auxiliary Hydraulics – Option		63.40 l/min
Tank capacities		
Fuel tank		47 l
Reservoir Capacity Hydraulics		30.30 l
Displacement		2.20 l
Coolant system capacity		7.60 l
LH Chain case		8.25 l
RH Chain case		8.25 l

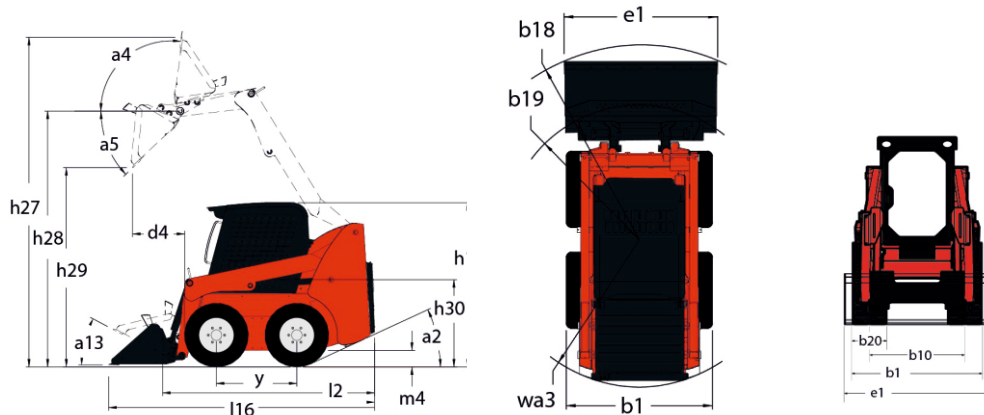

Effective Date: Sep, 2021. All dimensions, weights and timings are variable within 1.5%. Company reserves the right to change specifications without prior notice. The illustration do not necessarily show the standard version of the machine. Product specifications and prices are subject to change without notice or obligation. The photographs and/or drawings in this document are for illustrative purposes only. Refer to the appropriate Operator's Manual for instruction on the proper use of this equipment. Failure to follow the appropriate Operator's Manual when using our equipment or to otherwise act irresponsibly may result in serious injury or death. The only warranty applicable to our equipment is the standard written warranty applicable to the particular product and sale and we make no other warranty, express or implied.

MANITOU
HANDLING YOUR WORLD

Manitou Equipment India Pvt. Ltd.

Plot NO.22, Udyog Vihar, Greater Noida, P.O. Surajpur, Gautam Budh Nagar, U.P.-201306, INDIA

Tel.: +91-120-4194100 Fax: +91-120-2560541, Email: tepl.marketing@manitou-group.com Web: www.manitou-group.com

TOLL-FREE: 1800 103 7600

Your dealer:

