

# Linear Actuators

Model No : KS\_FY012

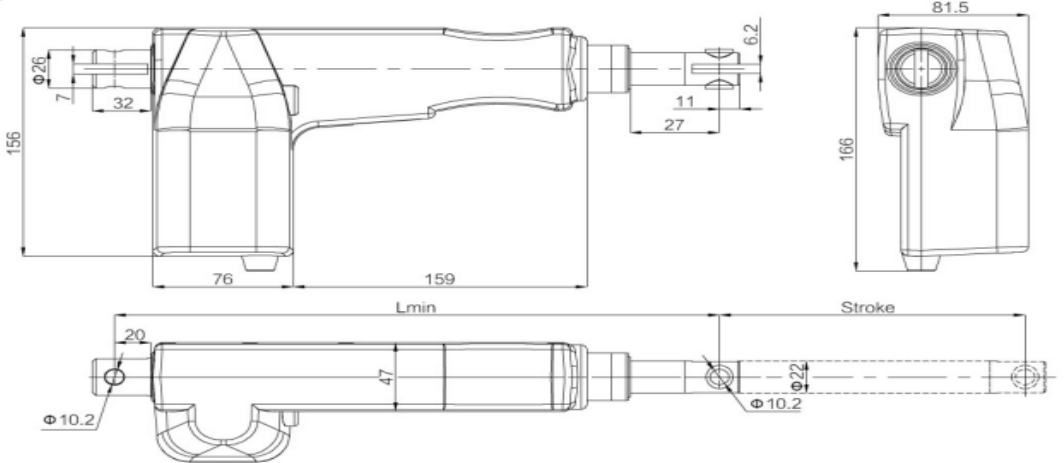

## Other Specifications:

### Application:

- Material Handling
- Factory Automation
- Packaging and converting

Free Load Speed	10 mm/s
Load capacity	2000N
Protection class	IP54
Duty cycle	2 min on or 18 min off
Stroke Length	100 mm

### Features:

- Compact design
- Aluminium frame and extension tube
- Built in limit switch
- Low Noise
- Electrical operation only