

Merritt Innovative Solutions India Pvt. Ltd.

Engineering Excellence



**Transportation &
E-mobility**



**Consumer
Goods**



Industrial



**Aerospace &
Defence**

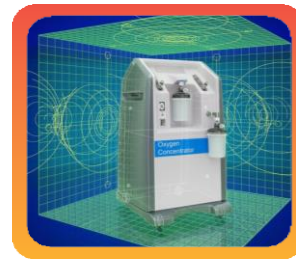

Healthcare



**IoT &
Analytics**

Management Team



Kumar Mahalingaiah
CEO & Managing Director



Kalidas Surapaneni
Director - Boston (US)



Anand Kallannavar
VP Technical Support

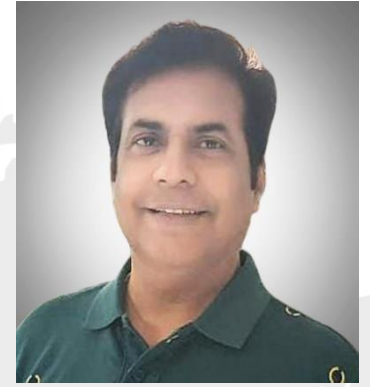

Ashoka K
Director Manufacturing

- ✓ *Industry veterans with decades of rich experience in the entire gamut of product development lifecycle*
- ✓ *Created an engineering centre of excellence to deliver solutions to complex global engineering needs*

Merritt snapshot



We engineer products that delight our customers



Quality



Cost



Speed of delivery

Deep engineering domain knowledge

“Innovation



that matters”

189 Products engineered

Merritt, an engineering integrator – customer centric strategy

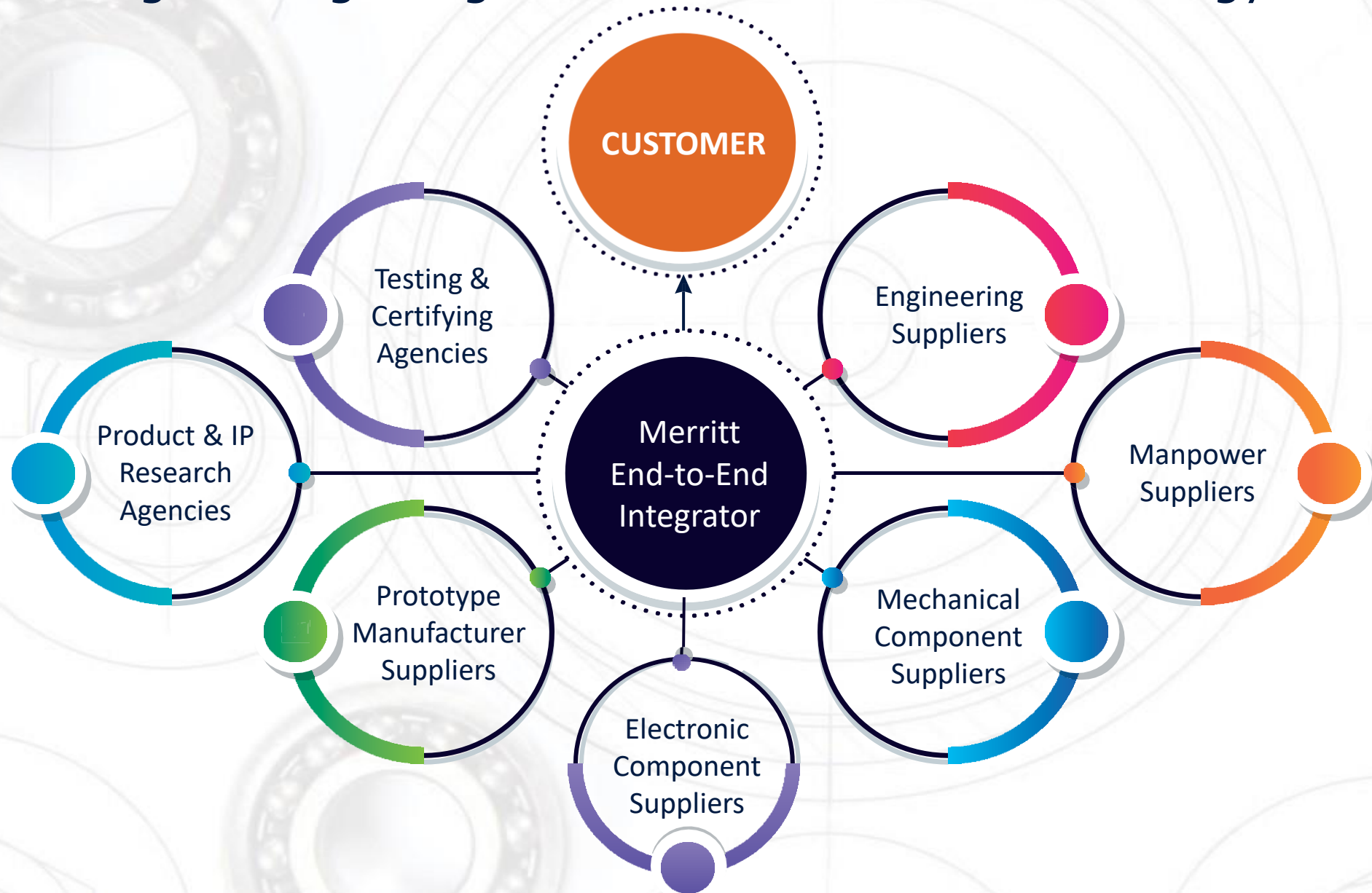

Partial list of our delighted customers



Product design and development experience

Transportation

2T rear axle for LCV, Gearbox for utility trucks, Garbage compactor

New product design

Defence

Pneumatic mast, Flat bed structures, Floating canopy, Trans axle gearbox

New product design/development

Consumer, Healthcare

Sewing machine (12 Mechanical and 8 Computerized), O2 concentrator

New product design and development

Construction & mining

Motor grader, GET, Backhoe loader rear axle (hub, brake assembly & shaft), Dust suppression system, Dump truck structure

New product design/development

Aerospace

Door latches, Hinge assemblies, Pre-charged cylinders, Hoses, Electronic products, Springs

Reverse engineering, CAD support

IIoT

IIoT devices (Vibration, noise and temperature), Biogas detector integration, Data collection node, Gateways

New product design and development

Material handling

50T trolley, power free & overhead conveyor, lift, & rotary tables, sidearm lifters, Bulk material handling, Ladle cover manipulator

New product design/development

Vacuum processing & Solar application

Solar thermal absorber coating unit, DST glass coating unit, Finger print coater, RRE sputtering chamber

New product design

SPM, Test rigs and Automation

Chip compactor, Welding manipulator, ER motor test rig, PCB test and programming fixtures, Automatic door latch test bed, Butterfly valve test rig and Automation

NPD and Automation

Engineering services offerings

CAD

Legacy conversion, migration, design automations, MBD, (SW, Auto CAD, Autodesk Inventor, NX, Catia, Creo,)

Should costing

Excel based costing,
Commodities: Machining, fabrication, plastics, sintered, castings, etc..

Proto build, test, prove-out & supply

Product compliance

CAE

Motion analysis (MBD)
Structural: Linear, Non linear, Vibrations, Thermal stress, Impact, Drop. CFD(Flow, Aerodynamic impacts), Thermal CFD

Teardown, reverse engineering

CT scanning, digital radiography, CMM, 3D scanning, material analysis, surface treatment analysis, gear measurement

Technical documentation

Parts catalogue, Operation and maintenance manual, assembly instructions, product brochures

Product integration

Sensors, PLC, Microcontrollers, HMI, safety interlocks

Re-engineering

Value Analysis,
Value Engineering (VAVE)

SCM, product commercialization & supply

Electronics product design, automation & controls experience



Automotive electronics

Payload Controller, Instrument Cluster with HMI, FOTA

New product design / development

Aerospace

Ramp and Hatch Actuation System - Motor Control Units, Integrated Control Module, Filter Board, Back plane & Power Supply

New product design and development

Consumer electronics & IoT

Unmanned Automated vending machine, Automated Coffee Vending machine

New product design

Defence

Analog Amplifier Development

Reverse engineering & Product development

Medical electronics

Biwaze cough system, IOT Ventilator

New product design / development

Automation & control systems

PLCs & HMI configuration & programming, DCS & SCADA, Instrumentation & controls, CNC control Systems and standalone servo drives

Services

IoT product development services



Partner support

CAD
Electro-Mechanical Enclosure, Sheet metal, Machined, Plastics, Rubber and Electrical contact, Right material and process selection, DFM & DFT, Product certification compliance

Integration and testing
Electro-Mechanical Product Integration, Functional Testing, and Burn-In

Software Consultancy
Solutions in technology-based, Resource and Support Services

CAE
Motion analysis (MBD)
Structural: Linear, Non-linear, Vibrations, thermal stress, Impact, Drop. CFD(Flow, Aerodynamic impacts), Thermal CFD

VAVE, Teardown, Reverse engineering
CT scanning, digital radiography, CMM, 3D scanning, material analysis, surface treatment analysis, gear measurement

Hardware Design & Development
Electronics and Embedded, Cable assembly, Design Validation, and Testing support, Mechanical Enclosures

Should costing
Excel-based costing,
Commodities: Machining, fabrication, plastics, sintered, castings, etc.

SCM, Product commercialization
Logistics and Delivery management

Proto build & Supply
Proto & Pilot batch, Production support
Product compliance and Certification



IEC 61010-1:2010
IEC 60079-0:2017
IEC 60079-7:2015

Design and developed products



GARBAGE COMPACTOR



TILTING TABLE



**CHAKKI MACHINE DESIGN
& OPTIMIZATION**

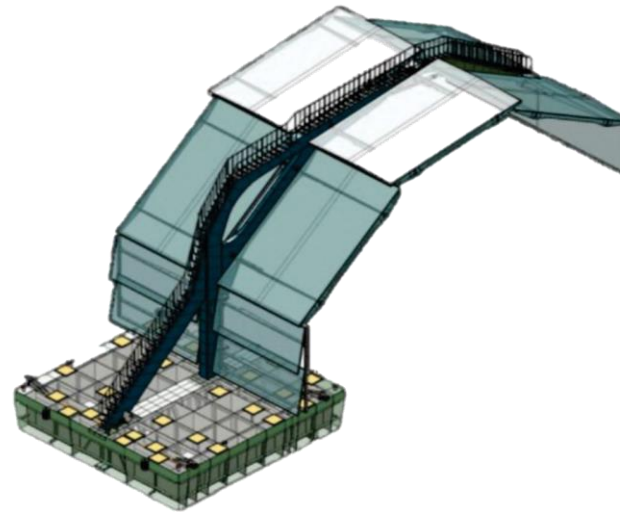

FLOATING CANOPY

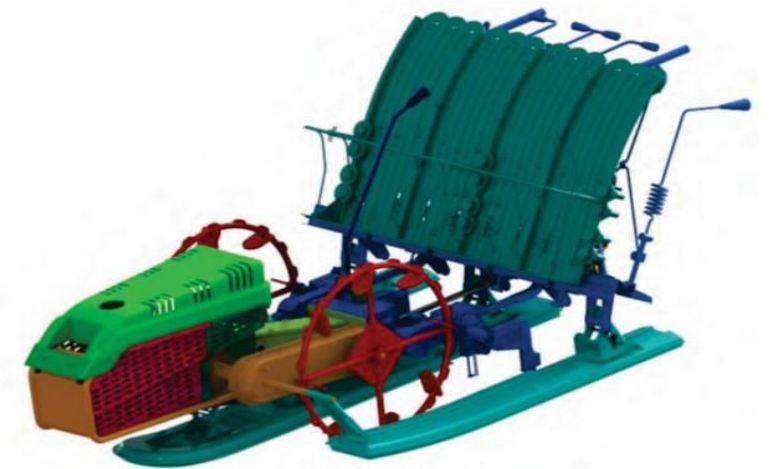

RICE TRANSPLANTER

Design and developed products

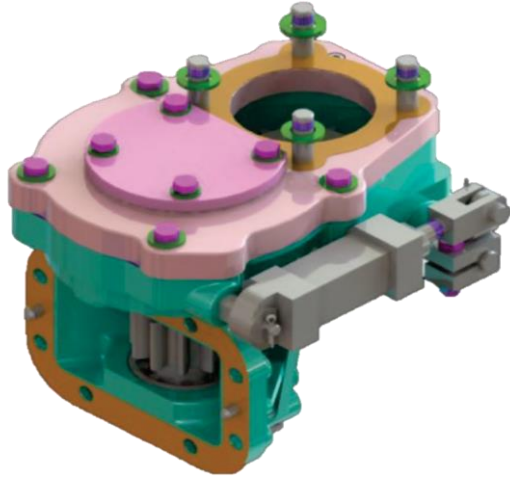

POWER TAKE-OFF

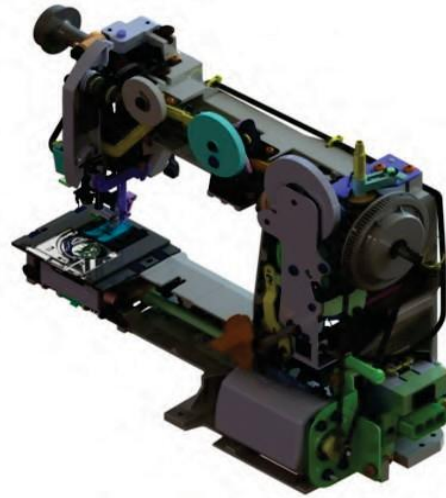

SEWING MACHINE

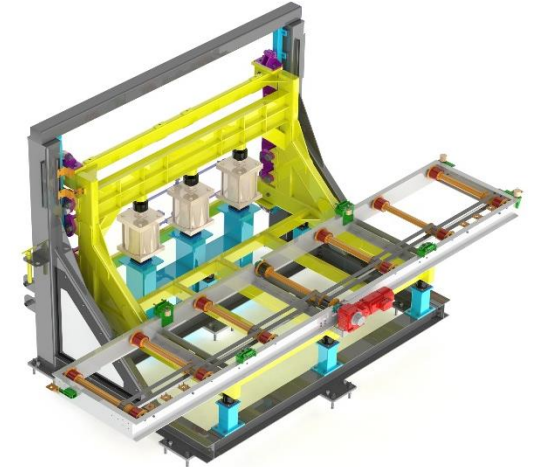

SIDE ARM LIFT TABLE



**MORTISE UNIT
TESTING FIXTURE**

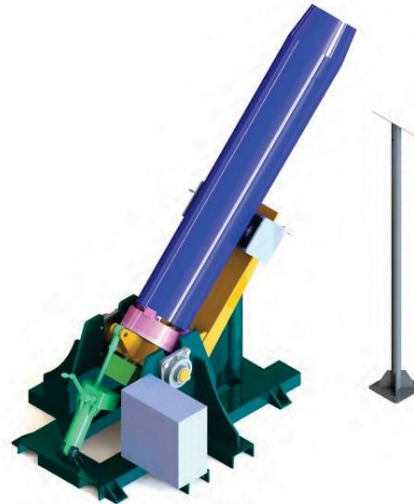

**MOTORIZED TILTING
WELDING FIXTURE**



SURGICAL INSTRUMENT

Thank You



Merritt Innovative Solutions India Pvt. Ltd.

#277, 4th Main , 4th Phase, Peenya industrial area, Bengaluru - 560 058