



CHEMICAL MORTAR  
**CM385/585**  
PURE EPOXY

# Chemical Mortar CM 385/585 PE

Pure Epoxy



## Description

The CM385/585 is a 2 component high strength pure epoxy chemical anchoring resin system. It is designed for deep embedment and large diameter holes due to its zero shrinkage and longer working times. For diamond drilled holes, with rebar, and in areas of high chemical exposure eg. Seasalt and swimming pools.

Available in Sizes: 385ml Cartridge or 585ml Cartridge.

## Specific Benefits

- Long working times
- High loads possible
- High chemical resistance
- Use with potable water
- Fixing studs in wood
- 24 Month shelf life
- Diamond drilled holes
- Zero shrinkage
- European approved
- Fire approved
- Studs and Rebar
- A+ Rating VOC content

## Approvals

- ETA Option 1 ETAG 001 for cracked concrete with studs and rebar TR029
- ETA Option 1 ETAG 001 for rebar TR023 : Approved for Seismic Loads C2
- F120 Fire Test report • ICC-ES Approval ESR 3853
- BS6920 for use with potable water WRAS Approved 1309522
- ETA approved in flooded holes, wet and dry concrete
- Tested according to LEED 2009 EQ c4.1, SCAQMD rule 1168 (2005).

Indo Spark Construction Services  
15  
1343-CPR-M-0582-4  
CM 385/585 PE  
ETA-17/0129  
ETAG 01-05 Option 1  
M8 - M30 / rebar Ø 6 to 32mm  
For use in cracked or non-cracked concrete  
Seismic Class C2

VOC CLASSIFICATION\*  
A+  
A+ A B C

WRAS  
APPROVED MATERIAL  
1501531

ICC  
ES

FIRE RATED R240

## TYPICAL GEL AND CURING TIME

T	Gel	Cure
40°C	10 min	150 min
35°C	16 min	240 min
25°C	25 min	480 min
15°C	60 min	1200 min
5°C	120 min	3000 min
0°C	N/A	N/A

For installation at -10°C cartridge must be 20°C

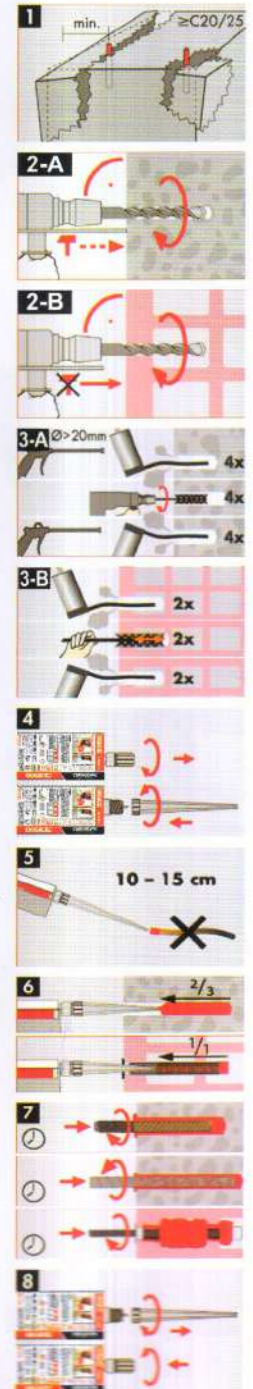

INDO CONSTRUCTION FASTENING SYSTEMS



INDO CONSTRUCTION FASTENING SYSTEMS

Typical characteristic and design resistance performance with 5.8 grade studding and associated installation data

Stud Ø (mm)	Characteristic Resistance (kN)		Design Resistance (kN)		Recommended Load (kN)		Characteristic Distances (kN)			Min Edge & Spacing (mm)		Nominal Embedment (mm)	Hole Diameter concrete (mm)	Hole Diameter fixture (mm)	Max. Torque (mm)
	Tension	Shear	Tension	Shear	Tension	Shear	Edge	Spacing	Edge	C <sub>min</sub>	S <sub>min</sub>				
	N <sub>ck</sub>	V <sub>rk</sub>	N <sub>td</sub>	V <sub>td</sub>	N <sub>rc</sub>	V <sub>rc</sub>	C <sub>cr,N</sub>	S <sub>cr,N</sub>	C <sub>cr,V</sub>	C <sub>min</sub>	S <sub>min</sub>				
M 8	19.00	9.00	12.70	7.20	9.07	5.14	80	160	80	40	80	10	09	10	
M 10	30.20	15.00	20.10	12.00	14.36	8.57	100	200	90	50	90	12	12	20	
M 12	43.80	21.00	29.20	16.80	20.86	12.00	120	240	110	60	110	14	14	40	
M 16	81.60	39.00	54.40	31.20	38.86	22.29	160	320	125	80	125	18	18	80	
M 20	127.40	61.00	84.90	48.80	60.64	34.86	200	400	180	100	170	24	22	120	
M 24	183.60	88.00	122.40	70.40	87.43	50.29	240	480	220	120	210	28	26	160	
M 27	238.00	115.00	159.10	92.00	109.52	65.71	270	540	240	135	240	32	30	180	
M 30	292.00	142.50	194.50	114.00	133.33	81.43	300	600	280	150	280	35	32	200	
M 33	342.12	173.50	162.91	138.80	116.36	99.14	330	660	310	165	300	37	36	250	
M 36	396.07	212.50	188.60	170.00	134.72	121.43	360	720	330	180	340	40	38	300	

High bond reinforcing bars Fyk=500N/mm<sup>2</sup>

Rebar Diameter (mm)	Hole Diameter (mm)	Embedment Depth hef																		h <sub>ef</sub> failure (mm)	f <sub>yk</sub> design load (kN)		
		60	70	80	90	100	110	120	130	140	160	200	240	280	320	400	500	560	640			720	800
8	10	11.7	13.7	15.6	17.6	19.6	21.5	23.5	25.2													129	25.2
10	12	14.7	17.1	19.6	22.0	24.4	26.9	29.3	31.8	34.2	39.1	39.3										161	39.3
12	15		19.1	21.8	24.5	27.2	30.0	32.7	35.4	38.1	43.6	54.5	56.6									208	56.6
16	20			26.8	30.2	33.5	36.9	40.2	43.6	46.9	53.6	67.0	80.4	93.8	100.6							300	100.6
20	25			28.7	32.3	35.9	39.5	43.1	46.7	50.3	57.5	71.9	86.2	100.5	114.9	143.6						438	157.1
25	30					41.1	45.3	49.4	53.5	57.6	65.8	82.3	98.7	115.2	131.7	164.6	205.7					549	226.0
28	35						50.7	55.3	59.9	64.5	73.7	92.2	110.6	129.0	147.5	184.3	230.4	258.1				668	308.0
32	40								68.5	73.7	84.3	105.3	126.4	147.5	168.5	210.7	263.3	294.9	337.1			763	402.1
36	44									79.2	90.5	113.1	135.7	158.4	181.0	226.0	282.8	316.7	362.0	407.2		902	510.0
40	50										95.8	119.7	143.6	167.6	191.5	239.4	299.2	335.1	383.0	430.9	478.8	1050	628.3
Depth (mm)		60	70	80	90	100	110	120	130	140	160	200	240	280	320	400	500	560	640	720	800		

Characteristic and Design Load resistances based on characteristic bond strengths for hef 4d (minimum embedment) to 20d

Stud Ø (mm)	Non Cracked Concrete						Cracked Concrete						Nominal Embedment (mm)
	Characteristic Resistance (kN)		Design Resistance (kN)		Recommended Load (kN)		Characteristic Resistance (kN)		Design Resistance (kN)		Recommended Load (kN)		
	Tension	Shear	Tension	Shear	Tension	Shear	Tension	Shear	Tension	Shear	Tension	Shear	
	N <sub>ck</sub>	V <sub>rk</sub>	N <sub>td</sub>	V <sub>td</sub>	N <sub>rc</sub>	V <sub>rc</sub>	N <sub>ck</sub>	V <sub>rk</sub>	N <sub>td</sub>	V <sub>td</sub>	N <sub>rc</sub>	V <sub>rc</sub>	
M 8	30.16	9.00	16.76	7.20	11.97	5.14	Not Applicable		Not Applicable		Not Applicable		80
M 10	42.41	15.00	23.56	12.00	16.83	8.57	Not Applicable		Not Applicable		Not Applicable		90
M 12	62.20	21.00	34.56	16.80	24.68	12.00	31.10	21.00	17.28	16.80	12.34	12.00	110
M 16	87.96	39.00	48.87	31.20	34.91	22.29	42.22	39.00	23.46	31.20	16.75	22.29	125
M 20	138.86	61.00	66.12	48.80	47.23	34.86	63.90	61.00	30.41	48.80	21.72	34.86	170
M 24	190.00	88.00	90.48	70.40	64.63	50.29	85.50	88.00	40.71	70.40	29.10	50.29	210
M 27	244.29	115.00	116.33	92.00	83.09	65.71	107.49	115.00	51.18	92.00	36.56	65.71	240
M 30	316.67	142.50	150.80	114.00	107.71	81.43	133.00	142.50	63.33	114.00	45.24	81.43	280
M 33	342.12	173.50	162.91	138.80	116.37	99.14	140.27	173.50	66.80	138.80	47.71	99.14	300
M 36	396.07	212.50	188.60	170.00	134.72	121.43	154.47	212.50	73.56	170.00	52.54	121.43	340



## Bond Strength Factors

Influence of concrete strength on combined pull out and concrete cone resistance

Concrete Strength N/mm <sup>2</sup> (Mpa)	C15/20	C20/25	C25/30	C30/37	C35/45	C40/50	C45/55	C50/60
fc =	0.98	1.00	1.02	1.04	1.06	1.08	1.09	1.10

Characteristic and Design Load resistance for Rebar based on characteristic bond strengths for hef 10d (min. embedment)

Rebar Ø (mm)	Non Cracked Concrete						Cracked Concrete						Nominal Embedment (mm)
	Characteristic Resistance (kN)		Design Resistance (kN)		Recommended Load (kN)		Characteristic Resistance (kN)		Design Resistance (kN)		Recommended Load (kN)		
	Tension	Shear	Tension	Shear	Tension	Shear	Tension	Shear	Tension	Shear	Tension	Shear	
	N <sub>rk</sub>	V <sub>rk</sub>	N <sub>rd</sub>	V <sub>rd</sub>	N <sub>re</sub>	V <sub>re</sub>	N <sub>rk</sub>	V <sub>rk</sub>	N <sub>rd</sub>	V <sub>rd</sub>	N <sub>re</sub>	V <sub>re</sub>	
8	22.12	13.95	12.29	9.30	8.78	6.64	Not Applicable		Not Applicable		Not Applicable		80
10	31.10	21.45	17.28	14.30	12.34	10.21	Not Applicable		Not Applicable		Not Applicable		100
12	41.47	31.05	23.04	20.70	16.45	14.79	22.81	31.05	12.67	20.70	9.05	14.79	110
16	59.69	55.50	33.16	37.00	23.69	26.43	28.05	55.50	15.58	37.00	11.13	26.13	125
20	96.13	86.55	45.78	57.70	32.70	41.21	42.30	86.55	20.14	57.70	14.39	41.21	170
25	148.44	135.00	70.69	90.00	50.49	64.29	63.83	135.00	30.40	90.00	21.71	64.29	210
28	209.36	168.75	99.69	112.50	71.21	80.36	87.93	163.75	41.87	112.50	29.90	80.36	280
32	273.44	220.95	130.21	147.30	93.01	105.21	112.11	220.95	53.39	147.30	38.13	105.21	320

## Bond Strength Factors - Rebar

Influence of concrete strength on combined pull out and concrete cone resistance

Concrete Strength N/mm <sup>2</sup> (Mpa)	C15/20	C20/25	C25/30	C30/37	C35/45	C40/50	C45/55	C50/60	C55/67	C60/75
fc =	0.98	1.00	1.02	1.04	1.06	1.08	1.09	1.10	1.10	1.12

Rebar Diameter (mm)	Rebar Bst 500 to DIN 488		Rebar Bst 500 to DIN 488	
	N <sub>rk,s</sub>	N <sub>rd,s</sub>	V <sub>rk,s</sub>	V <sub>rd,s</sub>
8	28.0	20.0	14.0	9.3
10	43.0	30.7	21.5	14.3
12	62.0	44.3	31.0	20.7
14	85.0	60.7	42.5	28.3
16	111.0	79.3	55.5	37.0
18	140.0	100.0	70.0	46.7
20	173.0	123.6	86.5	57.7
22	209.0	149.3	104.5	69.7
25	270.0	192.9	135.0	90.0
28	339.0	242.1	169.0	112.7
32	442.0	315.7	221.0	147.3
36	563.2	443.5	281.6	187.7
40	693.8	546.3	346.9	231.3



# Post installed Rebar schematics

## Application examples of Post-installed Rebar

**Figure 1 :** Overlap joints in slabs and beams.

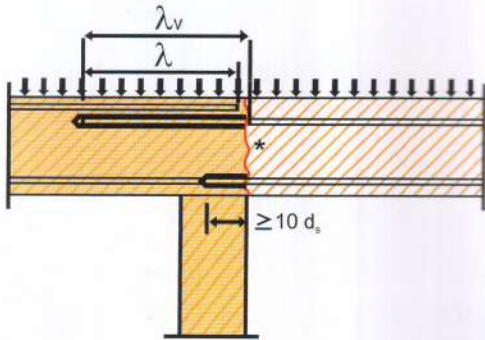

**Figure 3 :** End anchoring of slabs or beams, designed as simply supported.

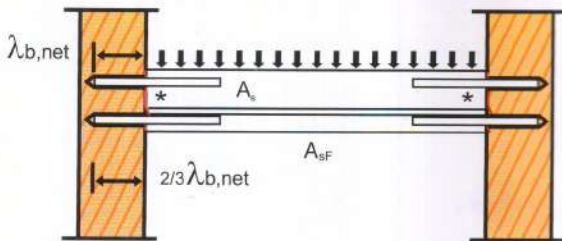

**Figure 5 :** Anchoring of reinforcement to cover the line of acting tensile force.

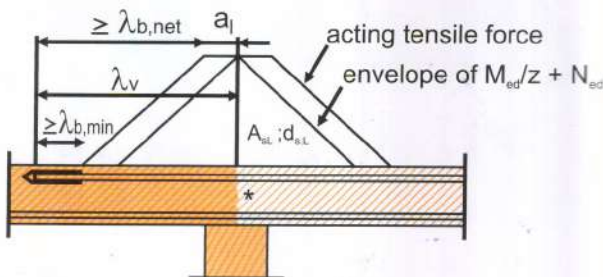

**Figure 2 :** Overlap joint in foundation of a column or wall where the rebars are stressed in tension.

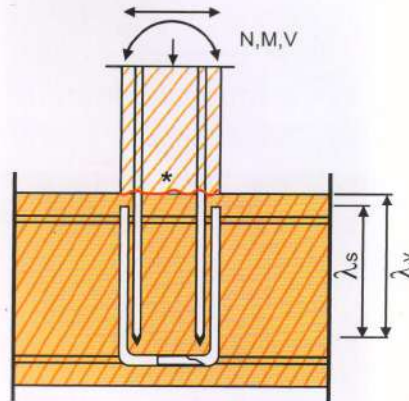

**Figure 4 :** Rebar connection of components stressed primarily in compression. The rebar are stressed in compression.

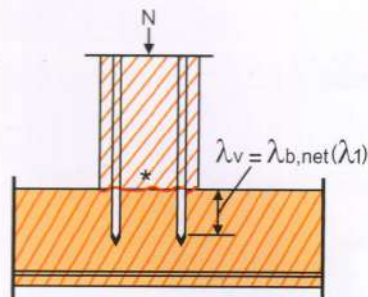

**Note to Figure 1 to 5 :**

In the figures no transverse reinforcement is plotted, the transverse reinforcement as required by EC 2 shall be present. The shear transfer between old and new concrete shall be designed according to EC2. Description of the bonded-in rebars and overlap joints see Annex 4 and 5.

\*Roughened joint



# Chemical Anchor Stud CAS

Steel, zinc plated/stainless steel A4-316



Chemical anchor CAS-E

## Description

The chemical anchor CAS is a chisel ended anchor for use with any of our injection systems and glass capsules in masonry and concrete. On installation the stud becomes chemically bonded to the base material. Notably the fixing method imposes no expansion stress on the base material and is ideal for shock or vibratory loading and for softer or low density building materials where expansion stresses would normally result in failure. The method also gives exceptional performance for close centre and close to edge fixing. The nut may be removed and replaced without affecting the anchorage. The chemical anchor CAS is supplied complete with high tensile hex nut and plain washer in addition to one external hex drive adapter in each box.

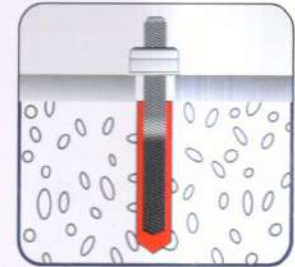

Product code Zinc plated 5.8 Grade	Anchor thread size(mm)	Anchor Length ( mm )	Hole Diameter ( mm )	Effective anchoring depth (mm)	Max.usable Length ( mm )	Width across nut (mm)	Hex nut (mm) SW	Washer in dia (mm)	Washer outer dia (mm)	Washer thickness (mm)	Package content pcs per Box
CAS08110E	M 08	110	10	80	13	5	13	9	15	1	25
CAS10130E	M 10	130	12	90	20	7	17	11	19	2	25
CAS10165E	M 10	165	12	90	52	7	17	11	19	2	25
CAS12160E	M 12	160	14	110	25	8	19	13	19.5	3	20
CAS12220E	M 12	220	14	110	90	8	19	13	19.5	3	20
CAS12250E	M 12	250	14	110	120	8	19	13	19.5	3	20
CAS16165E	M 16	165	18	125	13	12	24	17	29	4	10
CAS16190E	M 16	190	18	125	35	12	24	17	29	4	10
CAS16250E	M 16	250	18	125	98	12	24	17	29	4	10
CAS16300E	M 16	300	18	125	148	12	24	17	29	4	10
CAS16380E	M 16	380	18	125	235	12	24	17	29	4	10
CAS16500E	M 16	500	18	125	355	12	24	17	29	4	10
CAS20260E	M 20	260	25	170	65	12	30	21	36	4	10
CAS20350E	M 20	350	25	170	155	12	30	21	36	4	10
CAS20500E	M 20	500	25	170	305	12	30	21	36	4	10
CAS24300E	M 24	300	28	210	65	16	36	26	43	5	5
CAS24400E	M 24	400	28	210	165	16	36	26	43	5	5
CAS24600E	M 24	600	28	210	365	16	36	26	43	5	5
CAS27340E	M 27	340	32	210	165	18	41	28	49	5	5
CAS30380E	M 30	380	35	280	65	25	46	33	55	5	5
CAS30500E	M 30	500	35	280	185	25	46	33	55	5	5



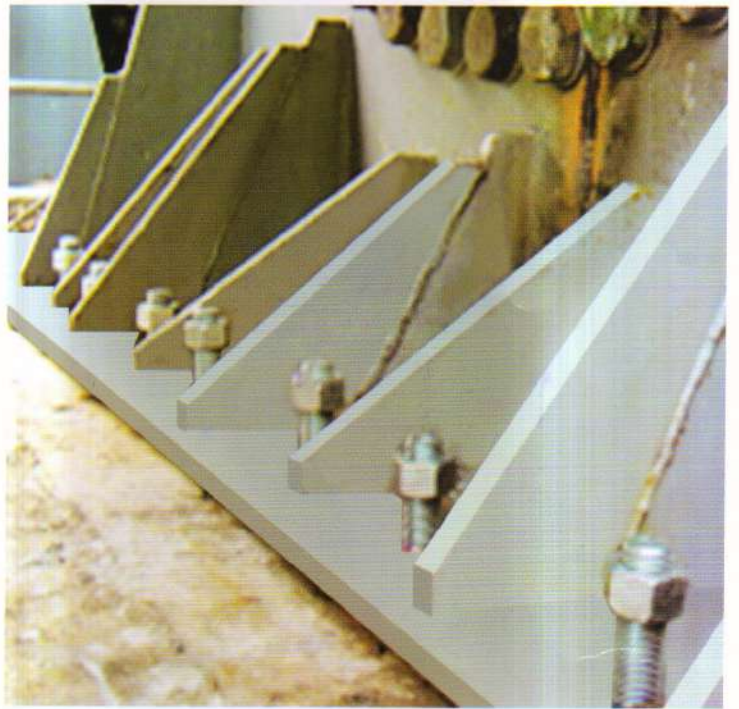
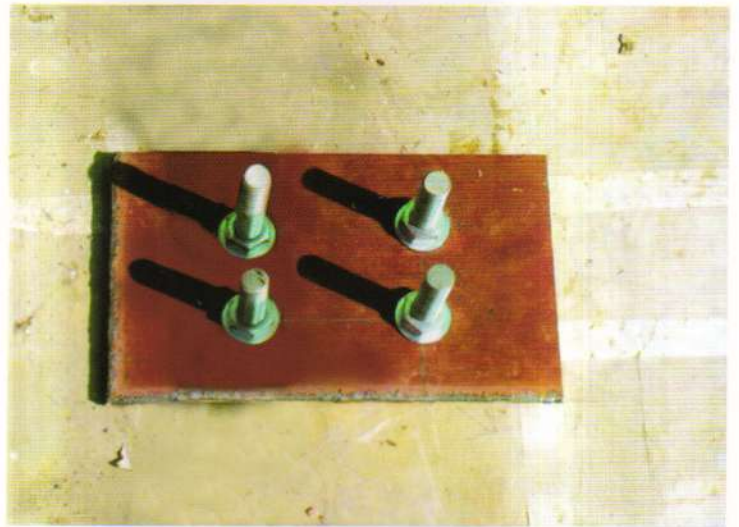
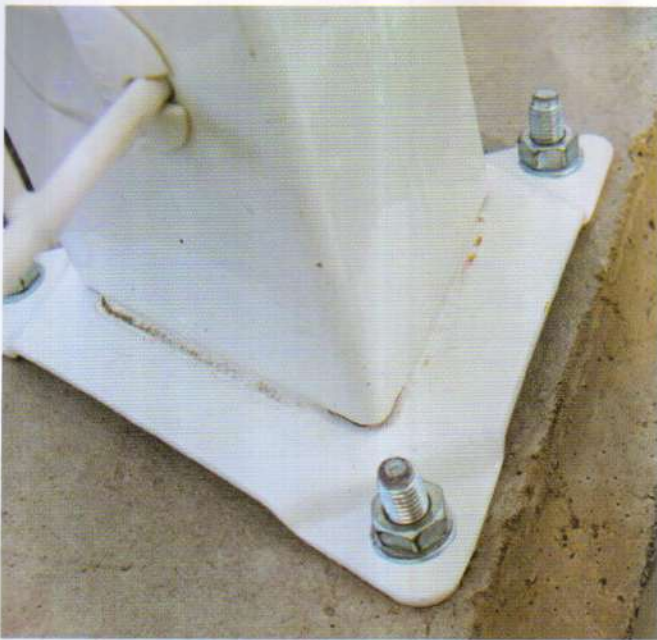
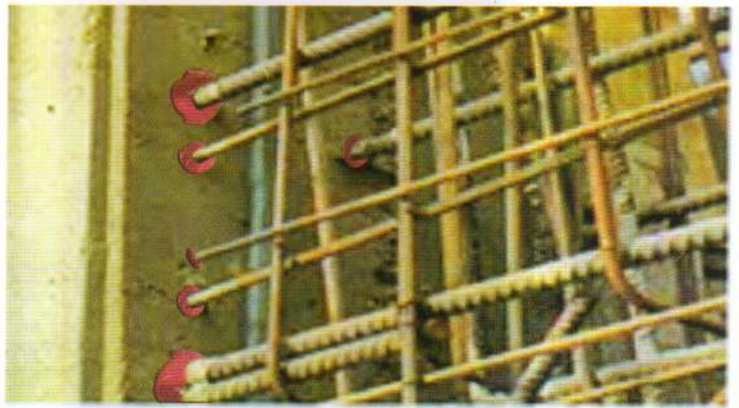

INDO CONSTRUCTION FASTENING SYSTEMS



INDO CONSTRUCTION FASTENING SYSTEMS

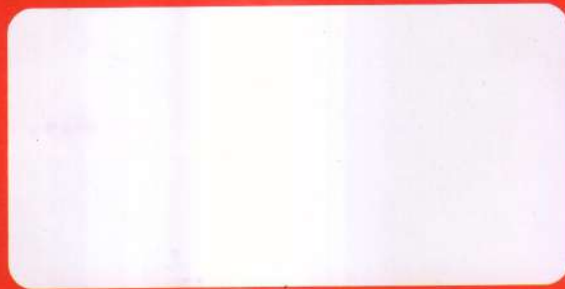

Marketed by :

 **INDO-SPARK**  
CONSTRUCTION SERVICES

Corporate Office : 198, E, Tararani Chowk, Nr Geeta Mandir, Kolhapur-416 003 (Maharashtra, India)  
Ph. No. 0231-2663581, 2654348, 2653908, Fax : 0231-6681005. E Mail : [mail@indospark.com](mailto:mail@indospark.com)

[www.indospark.com](http://www.indospark.com)